



This device complies with part 15 of the FCC Rules. Operation is subject to the following two conditions: (1) This device may not cause harmful interference, and (2) this device must accept any interference received, including interference that may cause undesired operation.

## SA-ATM-2 Stand-Alone Access Control System

The SA-ATM-2 is designed to read a specified number of digits from a magnetic stripe card and can accept up to 100 combinations of those digits.

### Setup

#### Step 1: Decide How Many Digits to Read

The first step is to tell the reader how many digits to read from the card. This is done by using J2 jumpers 1-3. Using the table on the right, set J2 jumpers 1-3 to the appropriate setting. Remove J2 jumpers 1 through 3 for "ATM" mode, grants access to any card with data on track 2.

J2 Jumper #	Description
1-3	Select Number of Digits
4	Strike Relay Duration
5	Not Used
6	Enroll Cards
7	Not Used
8	Delete All Cards

#### Step 2: Set Door Strike Timing

There are two door strike durations that are selectable by J2 jumper 4. When the J2 jumper 4 is "IN", the strike duration is 5 seconds. When J2 jumper 4 is "OUT", then the duration is 1 second.

Jumper 1	Jumper 2	Jumper 3	# of Digits
OUT	OUT	OUT	0
IN	OUT	OUT	1
OUT	IN	OUT	2
IN	IN	OUT	3
OUT	OUT	IN	4
IN	OUT	IN	5
OUT	IN	IN	6
IN	IN	IN	7

Now the reader is ready to accept card information.

### Card Maintenance

#### Enrolling New Card(s) to the System

To enroll a new card into the SA-ATM-2, first remove J2 jumper 6. Once removed, the LED on the reader flashes green. Now swipe each card to be enrolled, the reader will beep two times. When finished enrolling card(s), just replace J2 jumper 6. The LED on the reader will turn red and the reader will beep three times. The reader is now ready to be used.

#### Deleting the Card Database

To delete the cardholder database, just remove power from the unit and install J2 jumper 8. Apply power for 5 seconds and then remove power. Remove J2 jumper 8 and reconnect power. The card database is now empty. You must then re-enroll your cards.

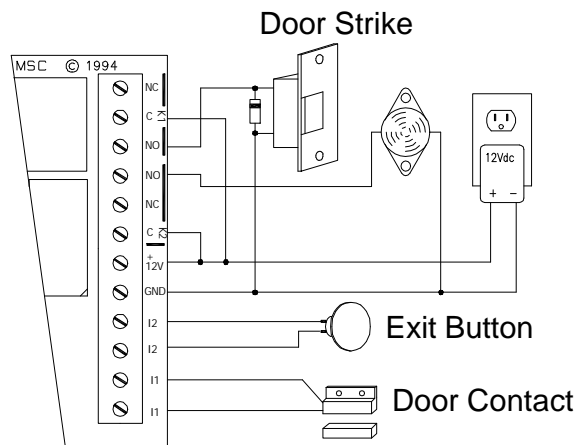

#### Reader Configuration Settings

The reader has a four dip switch block which must be configured. All four switches must be in the OFF position. When looking into the back of the reader, all switches should be pushed away.

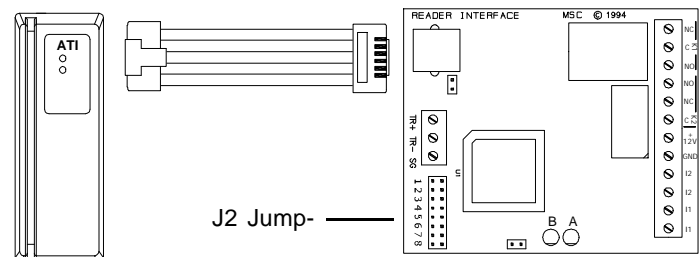

**CONFIDENTIAL:** For installation and maintenance use only. **DO NOT** distribute.

## Installation

Find a suitable location to anchor the reader mounting bracket. The mounting of the reader does not require a junction box. However, rigid conduit is required for outdoor application. A single gang junction box may be used to provide transition to rigid conduit. If a single gang junction box is used, a wall plate (optional) may be used to cover the junction box. The reader is then secured to the mounting bracket using a screw. Refer to figures for reader dimensions and typical junction box usage. Connect door hardware/power according to the configuration selected. Wires of 22AWG or larger are recommended for field wiring. See local electrical code.

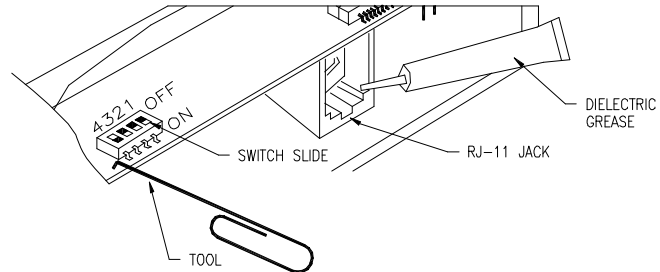

Coat reader connector with the silicone grease supplied to seal out moisture for outdoor mounting. To avoid having ESD (electrostatic discharge) interfering with the operation of the reader, the reader casing shall be grounded. This can be accomplished by tying the mounting bracket to earth ground locally (e.g. grounded conduit).

Reader Part Number: 36012-0000  
 Reader DIP switch setting: 4 3 2 1  
 (Factory Setting) OFF OFF OFF OFF

## Relay Contact Protection/Noise Suppression

Load switching can cause contact transfer, welding, and abnormal wear, which can cause premature contact failure. The switching of an inductive load (strike) can also cause EMI (electromagnetic interference). To prolong contact life and increase total system reliability, contact protection circuit must be used. The following two circuits are recommended. For DC application, use a diode circuit; for AC application, use a MOV (metal oxide varistor) circuit. Locate the protection circuit as close to the load as possible, as the effectiveness of the circuit will decrease if it is located too far away. As a guideline, the distance should be within 12 inches (30 cm).

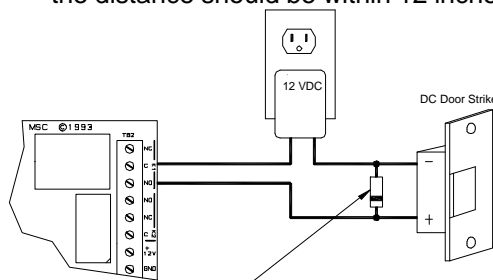

DIODE 1N4001 (50V/1A) TYPICAL

### DIODE SELECTION:

DIODE CURRENT RATING > 1X STRIKE CURRENT  
 DIODE BREAK DOWN VOLTAGE : 4X STRIKE VOLTAGE

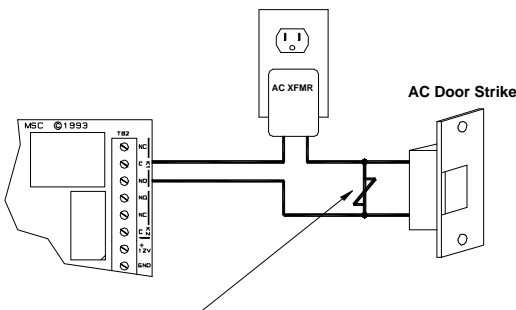

### MOV SELECTION:

VOLTAGE RATING > Vac RMS

FOR 24Vac STRIKE, PANASONIC ERZ-C07DK470



Access Technologies International, Inc. warrants that the product is free from defects in material and workmanship under normal use and service for two years from factory shipment. Access Technologies International, Inc. assumes no responsibility for products damaged by improper handling or installation. This warranty is limited to the repair or replacement of the defective unit.

There is no expressed warranties other than set forth herein. Access Technologies International, Inc. does not make, intends, nor does it authorize any agent or representative to make any other warranties, implied warranties, and expressly excludes and disclaims all implied warranties of merchantability of fitness for a particular purpose.

Returned units are repaired or replaced from a stock of reconditioned units. Returns must be accompanied by a return authorization number obtained from customer service, a purchase order and prepaid postage.

## LIABILITY

The card readers should only be used to control exits from areas where an alternate method for exit is available. This product is not intended for, nor is rated for operation in life-critical control applications. Access Technologies International, Inc. is not liable under any circumstances for loss or damage caused by or partially caused by the misapplication or malfunction of the product. Access Technologies International, Inc.'s liability does not extend beyond the purchase price of the product.

## Addendum - Revision C

This revision changed the door module to accommodate screw mounting instead of using snap track. The new module dimension is 4.25 x 2.75 inches.

Connection to the card reader is also changed from modular jack to a screw terminals for more convenient termination.

