

SA-2000-II

HARDWARE MANUAL

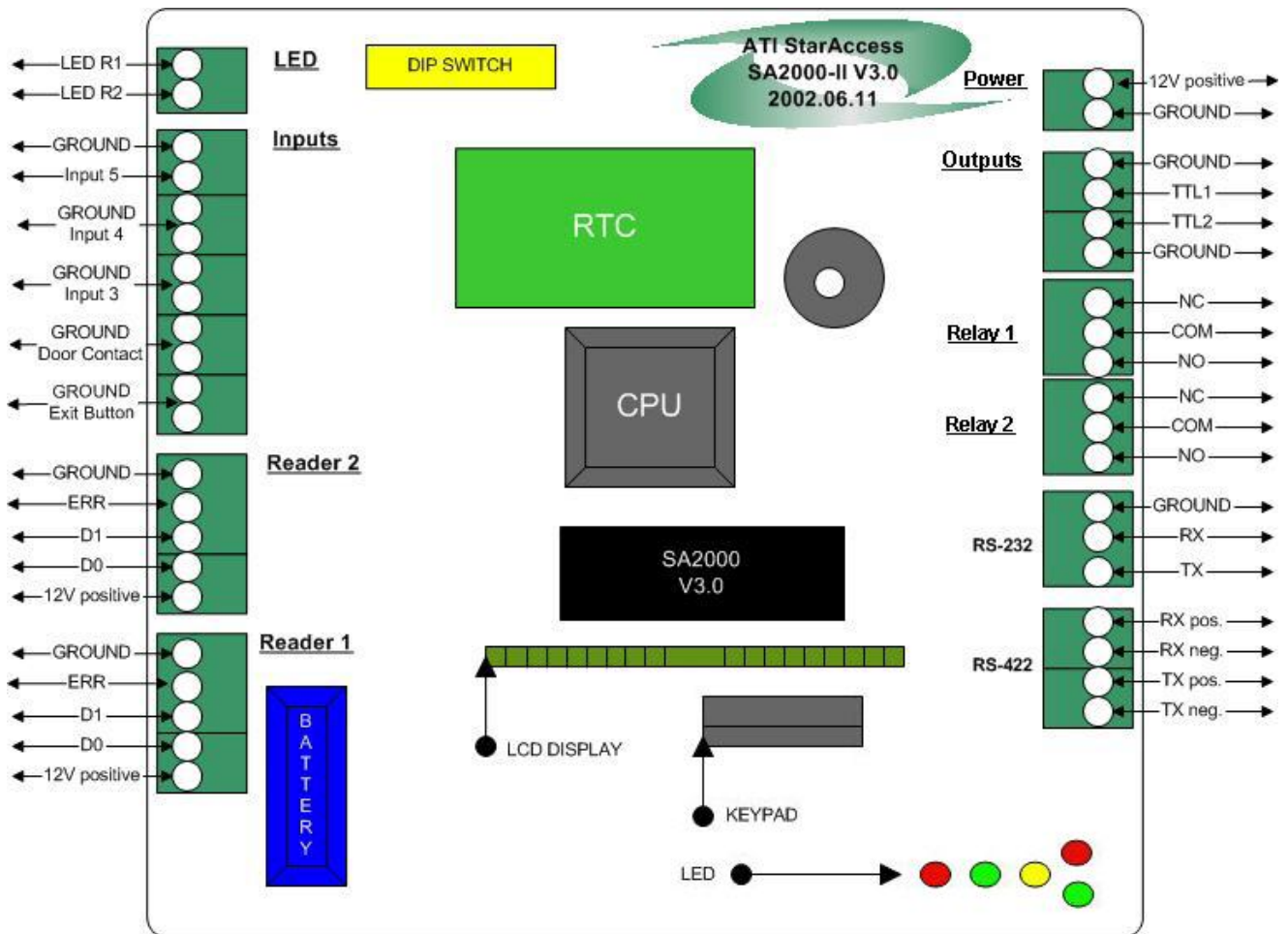

Access Technologies International, Inc.

Table of Contents

1. Introduction	3
2. Features	3
3. Specification	4
4. Identifying Supplied Parts	4
5. Panel Description	5
6. Connection	6
7. System Application	8
8. Wiring for Network	10
9. Functions	10
10. Operation	12
11. Important Safety Instructions	13
12. Operating status indications	13
13. Warranty and Service	14
14. Note	15

1. Introduction

The SA-2000-II is an intelligent two door access controller with a powerful 8-bit microprocessor to meet the market requirements for a simple and cost-effective access controller. It is designed to achieve high security, convenience and reliability. This user-friendly device allows you to register from 500 up to 10,000 ID numbers and it can store from 2,500 up to 7,250 events. Number of ID & Event can be exchanged dynamically under the ratio of 2 to 1 which means every 500 users can be converting to 250 events. It has 5 independent input points which could be connected with various devices such as exit button, door contact, PIR sensor, fire sensors, etc. The SA-2000-II has 5 output points including 2 Form-C Relays, and 2 TTL Relays (Changeable to 2 Form-C relays with the SA-2000-II-2RCB Relay Converter Board), and a panel buzzer. With an exit reader allows the Anti-passback feature to be operational. SA-2000-II can be used as not only a standalone access controller but also a network system communicating via RS-422 and RS-232 communication port. All setting values including ID numbers, inputs/outputs, real-time clock and time schedule, all event transaction reports can be downloaded or uploaded from/to the host computer. The SA-2000-II will provide you an accurate access control for a two door and 3 LED indicators inform you all system operating status at real time. The SA-2000-II access controller will give you field proven reliability and cost-effective solution wherever access controls and high security are required.

2. Features

- Two Door Control Panel
- 2 Reader ports with 26bit Wiegand format
- Data memory programmable
 - * Card holder records ----- 500 to 10,000
 - * Off-line stored events ----- 7,250 to 2,500
- Anti-Pass Back Operation
- Duress mode Operation
- Various Time Schedule Operations
- 5 independent input ports (Exit button, Door contact, Aux #1, Aux #2)
- 5 output ports including 2 Form-C Relays, 2 TTL, and a panel buzzer.
- All setting values are user programmable from the keypad or from the application software
- Door Lock and Unlock functions
- One RS-232 port and one RS-422 communication port for easy interfacing to Host computer
- Communication Address selectable up to 32 SA-2000-II panels
- Baud rate selectable at 4800, 9600(default), 19200bps
- 5 LED's (2 red, 2 green, and yellow) for system operation status
- Door open granted and Door open alarm

3. Specification

CPU	: 8bit Microprocessor
Memory	: Program memory (64KB ROM) Data memory (128KB RAM: battery backup)
Power	: DC 12V/ 150mA (max.)
Card Holders/Event buffers	: Memory programmable for: Card holder records ----- 500 to 10,000 Off-line stored events ----- 7,250 to 2,500
Reader ports/Data format	: 2 Reader port / 26bit wiegand format
Input/Output	: 5 Inputs (Exit button, Door contact, Aux #1, Aux #2), max. rating at DC12V/20mA : 2 Relay outputs: DC12V~24V/2A max. : 2 TTL outputs: DC5V/20mA : 1 Panel Buzzer
Communication	: One RS-232 port and one RS-422 port 4800, 9600 (default), 19200 bps Baud Rate.
LED	: 3 LEDs (red, green, and yellow)
Operating environment range	: -35°C to +65°C, 10% to 90% Humidity
Mounting	: 4-screw mount
Weight	: 170g
Dimensions	: 137mm (5.4 ") x137mm (5.4 ")
Self-diagnostic	: Yes
Reset	: Power on reset & watch dog timer
<u>Optional:</u>	
Keypad	: 16 Numeric Keypad
LCD	: 1x LCD module, 2Lines x 16ch, 65.6 x 13,8mm view area

4. Identifying Supplied Parts

Please unpack and check the contents of the box.

- 1.- Enclosure ENCL-2 with lock
- 2.- Power Supply LP-1
- 3.- 12v 5Amp Battery BAT-2
- 4.- Access Control Panel SA-2000-II panel
- 5.- Enclosure Lock

5. Panel Description

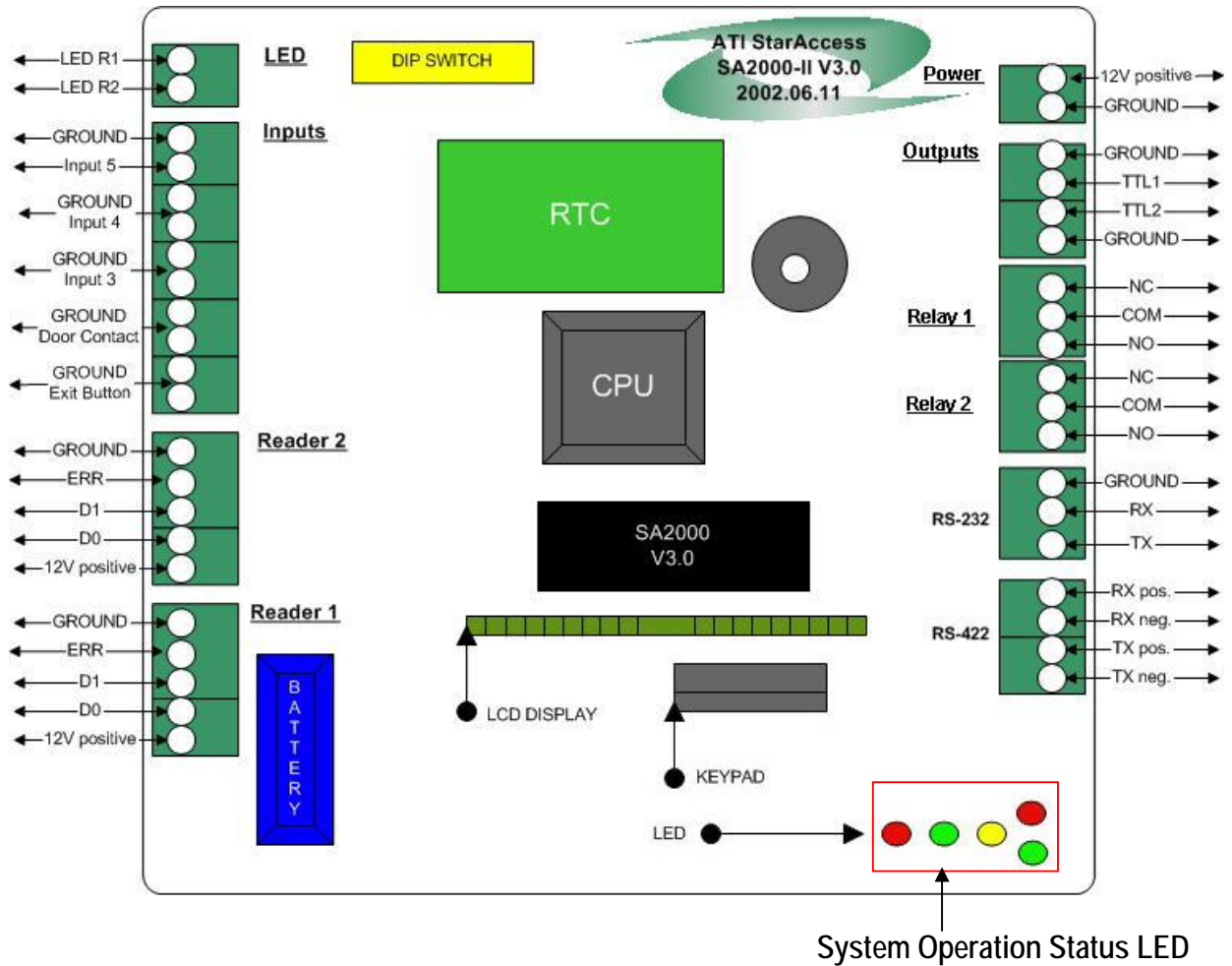

6. Connection

Setting SA-2000-II panel address

1. Initial status

Initial status of the DIP switch is as follows:

The address set by the DIP switch is to be used when operating with application program. It must be set equal to the corresponding programming for individual panel address. If necessary, see the application program manual.

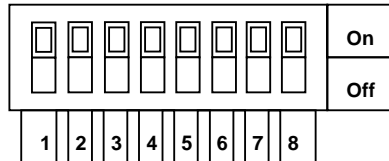

2. Addressing the unit

Table 1 : The relation between Setting and Dip switch

	00	01	02	03	04	05	06	07	08	09	10	11	12	13	14	15
1	On	Off	On	Off	On	Off	On	Off	On	Off	On	Off	On	Off	On	Off
2	On	On	Off	Off	On	On	Off	Off	On	On	Off	Off	On	On	Off	Off
3	On	On	On	On	Off	Off	Off	Off	On	On	On	On	Off	Off	Off	Off
4	On	On	On	On	On	On	On	On	Off	Off	Off	Off	Off	Off	Off	Off
5	On	On	On	On	On	On	On	On	On	On	On	On	On	On	On	On
6	On	On	On	On	On	On	On	On	On	On	On	On	On	On	On	On
7	On	On	On	On	On	On	On	On	On	On	On	On	On	On	On	On
8	On	On	On	On	On	On	On	On	On	On	On	On	On	On	On	On

	16	17	18	19	20	21	22	23	24	25	26	27	28	29	30	31
1	On	Off	On	Off	On	Off	On	Off	On	Off	On	Off	On	Off	On	Off
2	On	On	Off	Off	On	On	Off	Off	On	On	Off	Off	On	On	Off	Off
3	On	On	On	On	Off	Off	Off	Off	On	On	On	On	Off	Off	Off	Off
4	On	On	On	On	On	On	On	On	Off	Off	Off	Off	Off	Off	Off	Off
5	Off	Off	Off	Off	Off	Off	Off	Off	Off	Off	Off	Off	Off	Off	Off	Off
6	On	On	On	On	On	On	On	On	On	On	On	On	On	On	On	On
7	On	On	On	On	On	On	On	On	On	On	On	On	On	On	On	On
8	On	On	On	On	On	On	On	On	On	On	On	On	On	On	On	On

3. Initializing SA-2000-II controller.

Toggle the switch 8 to 'off' while the panel is power up. Turn off the panel then toggle dip switch back to its normal state 'ON' and turn the power on. Is not necessary but if you have an LCD screen connected to the SA-2000-II panel, you will see a message showing the initialization is completed (on the LCD, Press the <ESC> key and finish).

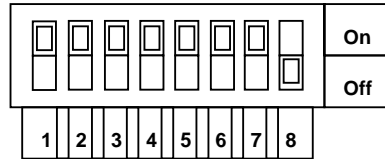

7. System Application

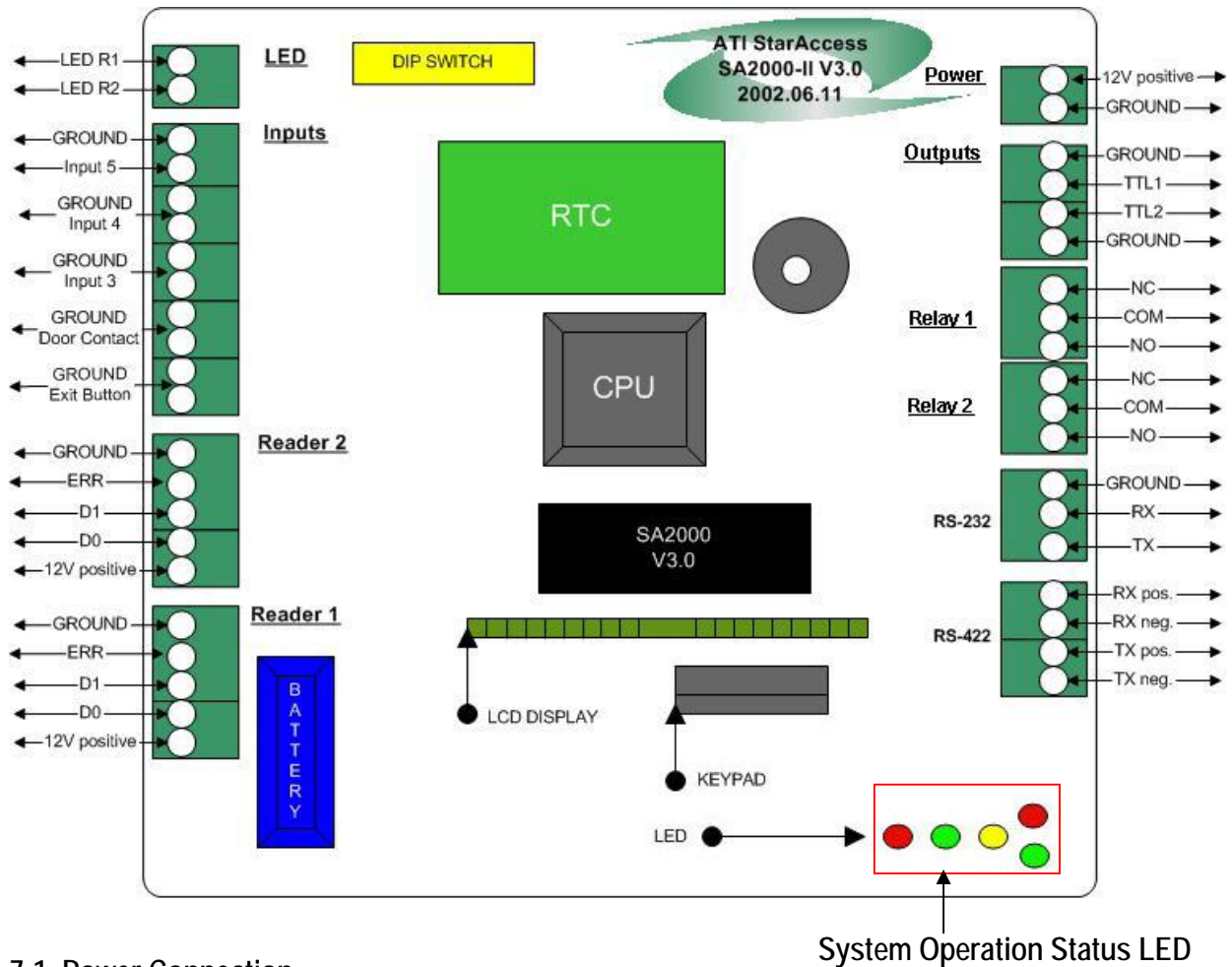

7-1. Power Connection

- Connect (+) wire of DC 12V power to +12V (terminal 1)
- Connect Power GND (-) wire of DC 12V to GND (terminal 2)

7-2. Door Lock Connection (Relay 1)

7-2-1 Connection of POWER FAIL SAFE: Door Lock

- Connect Door RELAY (common terminal) to DC +12V (be sure that the existing power supply has enough capacity to support this accessory or upgrade to a sufficient one.)
- Connect (+) wire of Door Lock to Door RELAY (N/O terminal).
- Connect (-) wire of Door Lock to Power GND (-) terminal.

7-2-2 Connection of POWER FAIL SECURE: Door Lock

- Connect Door RELAY (Common terminal) to DC +12V (be sure that the existing power supply has enough capacity to support this accessory or upgrade to a sufficient one.)
- Connect (+) wire of Door Lock to Door RELAY (N/C terminal).

- Connect (-) wire of Door Lock to Power GND(-) terminal.

7-3. Alarm Device Connection (Relay 2)

- Connect Alarm RELAY (Common terminal) to DC +12V (be sure that the existing power supply has enough capacity to support this accessory or upgrade to a sufficient one.)
- Connect (+) wire of Alarm Device to Alarm RELAY (N/O terminal) wire.
- Connect (-) wire of Alarm Device to Power GND (-) wire.

7-4. Exit Button Connection

- Connect one of the wires of Exit Button to Exit Button Input.
- Connect the other wire of Exit Button to Power GND(-).

7-5. Door Contact Sensor Connection

- Connect Door Contact sensor (Common) wire to Door Contact Input.
- Connect Door Contact sensor (N/O) wire to Power GND(-).

7-6. Auxiliary Input Device Connection (Applied to Input 1, 2)

- Connect one wire of the Auxiliary Input Device to the Input (Input 1, 2).
- Connect the other wire of Auxiliary Input Device to Power GND(-).

7-7. Wiegand Input Connection From Wiegand Reader (1, 2)

- Connect (+) wire of Reader (1, 2) to +12V port of Main Unit.
- Connect (-) wire of Reader (1, 2) to GND (-) port of Main Unit.
- Connect Wiegand output DATA0 wire of the additional Reader (1, 2) to DATA0 (Reader 1, 2).
- Connect Wiegand output DATA1 wire of the additional Reader (1, 2) to DATA1 (Reader 1, 2).
- **When installing readers, reader 1 set for entry and reader 2 set for exit.**

* **Qualified card readers:** 26bit wiegand format reader
EXAMPLE: HID, ATI, KERI, AWID, MOTOROLA, etc.

7-8. RS-232 Communication Port Connection

9-pin connector (COM Port, female) is required to connect serial communication RS-232 between Main Unit and Personal Computer.

- Connect RS-232-TX of main unit to pin number 2 of 9-pin connector.
- Connect RS-232-RX of main unit to pin number 3 of 9-pin connector.
- Connect RS-232-GND of Main Unit to pin number 5 of 9-pin connector.
- Plug in 9-pin connector to COM1...COM8 Port of Personal Computer.

7-9. RS-422 Communication Port Connection

RS-422/RS-232 converter is required to connect serial communication RS-422 between Main Unit and Personal Computer.

- Plug in RS-232 9-pin connector of RS-422/RS-232 converter to COM1 or COM2 Port of Personal Computer.
- Connect RS-422-TX(-) of Main Unit to RX(-) port of converter.
- Connect RS-422-TX(+) of Main Unit to RX(+) port of converter.
- Connect RS-422-RX(-) of Main Unit to TX(-) port of converter.
- Connect RS-422-RX(+) of Main Unit to TX(+) port of converter.

- Install and run Application Software.

8. Wiring for Network

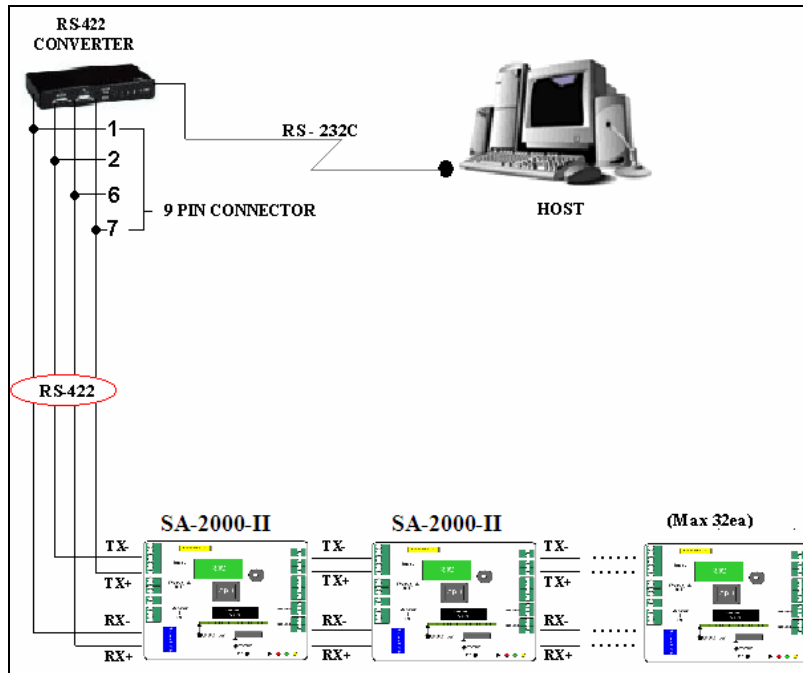

9. Functions

9-1. Standalone Operation

The SA-2000-II is capable of having two readers (entry and exit). The unit receives card data signals from the readers and determines whether or not to unlock the door. When an input signal is sent, for example from an activated sensor or an exit button, the controller generates and logs an appropriate response. All events are kept in memory and sent to the host computer. The access controller is a true standalone device that in the event of a malfunction will not affect other units.

9-2. Operation with Host Computer

All event data can be managed via the host computer. The data transmitted from the controller can be displayed and stored on the host PC.

9-3. Keypad

In the event that a host PC is not used, an optional integrated keypad and LCD can also be used for the entire programming process.

9-4. Cooperation with Fire Detection Equipment

The SA-2000-II access controller and fire detection equipment can cooperate to unlock the door in case

of fire.

9-5. Anti-Passback

Using an additional reader for exiting, the Anti-Pass-Back mode can be utilized. This feature reduces the likelihood that two or more people can use the same access credential to gain admission to a controlled area. This is done by requiring that the credential be presented upon entrance to an area and again when leaving the area. If the same credential is used for two entrances without an exit in between, an alarm is sounded.

9-6. Data Backup

The controller retains all user information and event data for over a week, even if the event of loss of power. Using a battery back up the unit can operate normally for a significant time period, depending on the power of the battery used.

9-7. Inputs/ Outputs

The SA-2000-II access controller has five input ports, and 5 output ports (two relays, two TTL outputs, and one panel buzzer output) that can be used to manipulate a wide variety of controls.

9-8. Time Schedule

You can program periods of time when each person (ID number) can access the door. Each user can be programmed individually to address work shifts, weekends and holidays. All scheduling can be programmed through the keypad and LCD or via the software program on the host computer. Also you can set periods of time about output following input, and only output, the former correspond to Input, the latter correspond to Output. So, you can set Input and Output according to each T/S. All these can be defined through the setup menu or application program.

9-9. Output Behavior Setup

The two relays outputs, two TTL outputs, buzzer sound, etc. is customizable. They may be activated or deactivated, and in active mode may be programmed for different lengths of time, different responses to inputs, and can be set through the setup menu or the application program.

9-10. Door Open by Compulsion and Door Open Alarm

When door is opened by compulsion, Door Contact output is generated. And, when the door is being opened by normal operation, after 20 sec. door-open alarm (blink buzzer) will be generated until the door is closed.

9-11. Duress Mode

In case of Duress, enter the 2 digits Duress Password and press <ENT> and open the door using general process. If you registered ID, then duress output will be generated.

9-12. Programmable ID/EVENT memory

This user-friendly device allows you to register 500 ~ 10,000 ID numbers and it can keep 2,500 ~ 7,250 events. Number of ID & Event can be exchanged under the ratio of 2 to 1 which means every 500

users can be convert to 250 events.

10. Operation

10-1. Normal Operation Mode (Safe Mode)

When the Main Unit operates in standby mode (waiting for card input), the red LED is lit.



10-2. Open the Door

When a valid card (or PIN) is read, the Door will open for 3 seconds. (default)



Reader



3 Seconds

Valid Card

10-3. Exit (Open the Door)

To request for exit from the inside, an Exit Button (or Exit Reader) can be used to open the door.



Reader



Exit Button



3 Seconds

Valid Card

10-4. Action And Alarm Caused by invalid Card

When an invalid card is read the access is denied and the alarm can be activated for 3 seconds along with a buzzer sound.



Reader

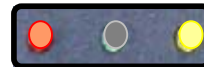

3 Seconds

Invalid Card

(If you do not want to activate the Alarm in case of unregistered access attempt, then you can change this setting.)

11. Important Safety Instructions

When using your SA-2000-II, basic safety precautions should always be followed to reduce the risk of fire, electrical shock, and injury to persons. In addition, the following safety guides should also be followed:

1. **Fully** read and understand all instructions and follow them completely.
2. **Follow** all warnings and instructions marked on the product.
3. **Do not** use liquid or aerosol cleaners. Use a damp cloth for cleaning. If necessary, use mild soap.
4. **Do not** use this product near water.
5. **Only** operate this product using the type of power source indicated. If you are not sure of the type of power supplied to your installation site, consult your dealer or local power company.
6. **Never** insert objects of any kind into the product or through the cabinet slots as they may touch voltage points and/or short circuit parts possibly resulting in fire or electric shock. Never spill liquid of any kind on the product.
7. **Never** disassemble this product by yourself; take the unit to a qualified service center whenever service or repair is required. Opening or removing the covers may expose you to dangerous voltages or other risks. Also, incorrect reassembly can cause electric shock when the unit is subsequently used.
8. **Unplug** this product from the Direct Current (DC) power source and refer to qualified service personnel under these conditions:
 - a. When the power supply cord or plug is damaged or frayed.
 - b. If liquid has been spilled on the product.
 - c. If the product does not operate normally after following the operating instructions in this manual. Adjust only those controls that are covered by the operating instructions in this manual. Improper adjustment of other controls that are not covered by this manual may damage the unit and will often require extensive work by a qualified technician to restore normal operation.
 - d. If the product exhibits a distinct change in performance.

12. Operating Status Indications

Granted Access	: Displayed when an access is granted.
UNREGISTERED CARD	: Displayed when an unregistered card (PIN) is present to unit.
SCHEDULE ERROR	: Displayed when a Time Schedule error occurs.
APB ERROR	: Displayed when an anti-pass back error occurs.
PASSWORD ERROR	: Displayed when an invalid password is entered.
ACCESS DOOR ERROR	: Displayed when a registered card (or PIN) that is supposed to access the other reader is presented to the reader. This may occur if 1 or 2 is entered for the RD value when the card was being registered.

13. Warranty and Service

SA-2000-II warranty is 2 years from the shipped date; returns must have an RMA (Return Material Authorization) number. The customer is to provide a description of the specific problem. The customer is to include serial numbers, formats, and model numbers with the items to be returned.

Contact Technical Support



ACCESS TECHNOLOGIES INTERNATIONAL, INC.

840 North Old World Third Street, Suite 600

Milwaukee, WI 53203

Tel.: (414) 289-3121

Fax. (414) 289-3129

E-mail: ati@atiaccess.com

Web-site: www.atiaccess.com.com

Note: Damage occurring during shipment is deemed the responsibility of the carrier, and claims should be made directly to the carrier.

MEMO